

NEW PRODUCT

HOT PRESS, TOTALLY INTERNALLY FLANGED (IF).



TRICEL
GENERATIONS OF INNOVATION

IDEAL FOR LIMITED SPACE APPLICATIONS AND IMPROVES CAPACITY. AVAILABLE UP TO 2M HIGH.

Tank Support & Clearance Requirements

A Totally Internally Flanged tank can be placed directly on to a continuous flat surface e.g. plinth or tank room floor providing that the surface does not vary more than 2mm in any 1m or a total of 6mm in any 6m, measured laterally or diagonally.

The completed base structure shall be capable of supporting the weight of the tank and its maximum water load i.e. filled to the brim, along with any potential wind or snow loads as applicable.

If foundations are to be provided by suspended floors or beams, then the foundation should be constructed so that when the tank is full, the combined deflections should not exceed 1/500th of the span (BS EN 13280:2001).

Alternatively, if the plinth tolerance cannot be achieved, the use of levelling steels will allow you to take up any irregularities with shims up to a maximum of 18mm.

Our standard levelling steels are 100mm x 50mm high galvanised box section and must be fully supported (non-spanning) and positioned at 500mm centres.

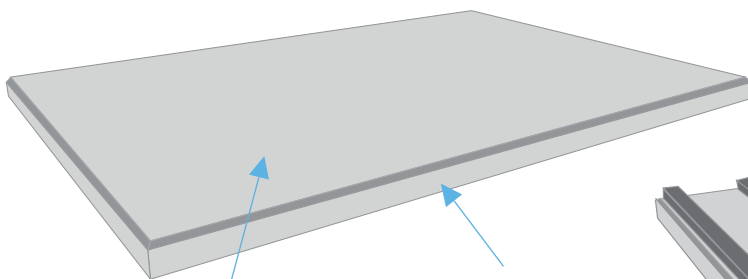
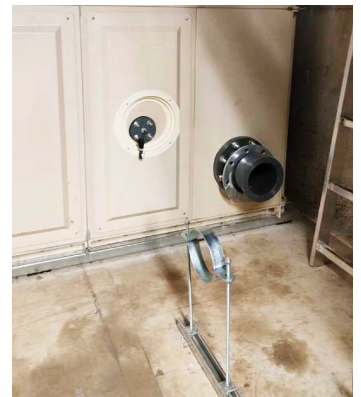
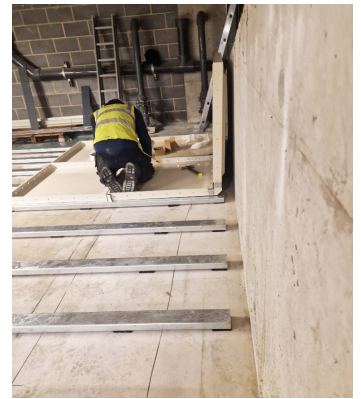

Primary support

Surface variance not more than 2mm in 1m AND no more than 6mm in 6m

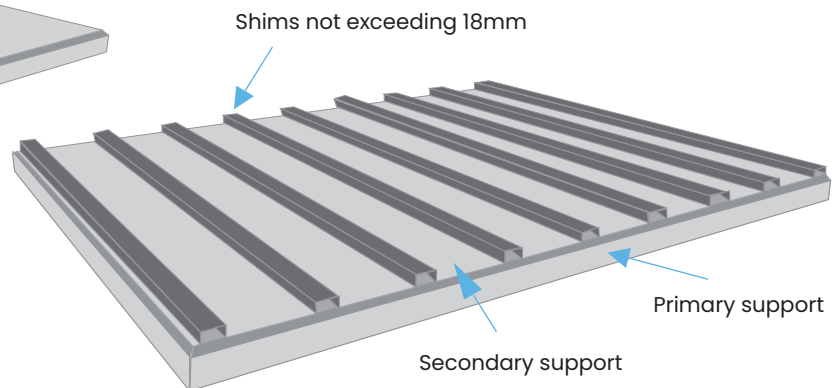

Shims not exceeding 18mm

Secondary support

Primary support

For more information contact us today at:
sales@tricelwater.co.uk or tricelwater.co.uk



CLEARANCE REQUIREMENTS.

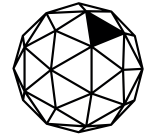

TRICEL
GENERATIONS OF INNOVATION

For Installation and future maintenance

This style of tank is ideal where space is limited and can be pushed within 50mm of a wall.

The minimum clearance requirements taken from the external measurements of the tank are 50mm on 3 sides, minimum 500mm (*1000mm when fitted with a hooped ladder) on the 4th side to accommodate pipework and 750mm headroom clearance for safe access (**1200mm when fitted with Guardrail)

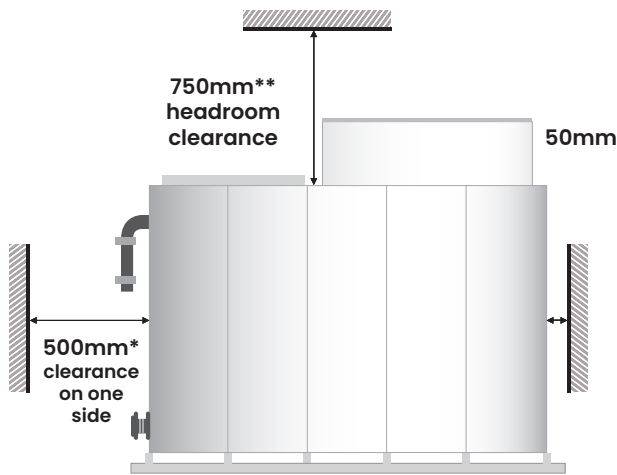

Plan view of tank with clearance measurements

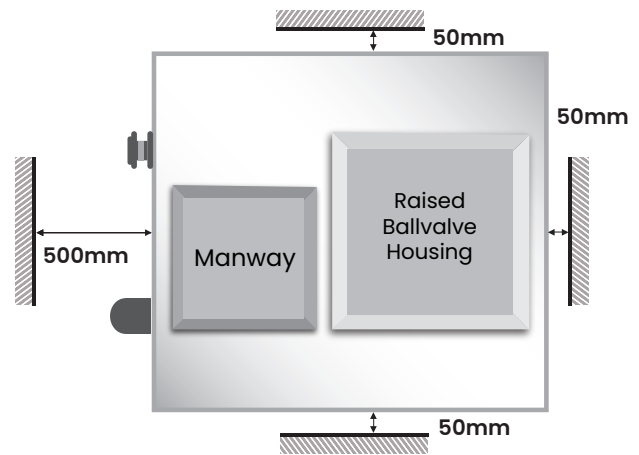

Plan view of tank with clearance measurements

1234567 / 0-UK-APR 2024

For more information contact us today at:
sales@tricelwater.co.uk or tricelwater.co.uk

TRICEL LANARK

Riverside Road, Kirkfieldbank,
Lanark, ML11 9JS,
United Kingdom.

T: +44 (0) 1934 421 477
E: sales@tricelwater.co.uk

TRICEL WESTON

Winterstoke Road,
Weston-super-Mare,
BS24 9AN, United Kingdom.

T: +44 (0) 1934 421 477
E: sales@tricelwater.co.uk

TRICEL CROYDON

10 Tait Road,
Croydon, CR0 2DP,
United Kingdom

T: +44 (0) 1934 421 477
E: sales@tricelwater.co.uk

PUMPING SOLUTIONS

TRICEL PORTSMOUTH

Unit 14, Arnside Road,
Waterlooville, Hampshire,
PO7 7UP, United Kingdom

T: +44 (0) 196 258 7244
E: websales@tricelpumps.co.uk