



# TRICEL

GENERATIONS OF INNOVATION

## GRP WATER STORAGE **PRODUCT GUIDE**



[sales@trichelwater.co.uk](mailto:sales@trichelwater.co.uk) | [trichelwater.co.uk](http://trichelwater.co.uk)

# Contents

Welcome to Tricel .....	2
The Tricel Group – A Brief History .....	3
Location Map .....	5
Accreditations .....	7
Standard One Piece Tank Range .....	8
Standard Two Piece Tank Range .....	11
Cube TIF Tanks .....	12
GRP Sectional Combined Tank & Pump Station .....	14
One Piece Combined Tank & Pump Station .....	16
LPCB Tanks .....	18
GRP Sectional – Cold Water Storage Tanks .....	19
Hot Press, Totally Internally Flanged (IF) .....	21
Hot Press, Internally Flanged Base (IFB) .....	23
Totally Internally Flanged (TIF) .....	25
TIF Case Study .....	27
Totally Internally Flanged (TIF) c/w Self-Draining Externally Flanged Base .....	29
Hot Press – Self-Draining Externally Flanged Base (EFB) .....	31
Hot Press – Truncated Externally Flanged Base (EFB) .....	33
The Whole Package – Booster Enclosure & Sectional Tank .....	35
Tricel – Looking after your Pumping Needs .....	36
Tricel Environment .....	41
Construction Products .....	43
Tricel Distribution .....	45



# TRICEL

GENERATIONS OF INNOVATION

Welcome to Tricel, where innovation meets excellence in providing products and solutions for the Water, Environmental, Construction, and Distribution industries. Since 1973 in Killarney, Ireland, we've grown into a global leader with 17 locations across Europe and the UK, including seven manufacturing sites, serving clients in 50 countries. Our values of "Generations of Innovation" reflect our commitment to Innovation, Quality, and Heritage, built over 50 years of success.

Today, Tricel is recognised globally for delivering high-performance solutions in industries like wastewater treatment, water storage, meter boxes, and road safety. Our expertise extends to composite materials and lubricants, ensuring a wide range of products and services.

Our proficiency in Glass Reinforced Polyester (GRP) and leadership in Sheet Moulding Compound (SMC) processes set us apart, driving innovation for our customers.

At Tricel, we don't just solve problems – we deliver solutions that exceed expectations. Join us in pursuing excellence and innovation.



For more information contact us today at:

[sales@tricelwater.co.uk](mailto:sales@tricelwater.co.uk) or [tricelwater.co.uk](http://tricelwater.co.uk)

# The Tricel Group – A Brief History



## **Killarney Plastics Origins:**

Founded by Anne and Con Stack in 1973, Killarney Plastics initially focused on high-quality composite and fibreglass (GRP) products, a cutting-edge material revolutionizing the Irish market. Starting small, the company produced a range of items, including boats and motorbike fairings, for the local community.

## **1980s Growth:**

As demand grew, Killarney Plastics moved to a larger facility and expanded its product range to include water storage tanks and meter enclosures. This period marked the company's transition toward innovation and more sophisticated manufacturing methods.

## **1990s Expansion:**

The company made its first export sales to the UK and Europe, establishing its reputation in engineering and securing contracts with utilities. In 1997, Fibreglass Sales was established in Northern Ireland, followed by the formation of Killarney Manufacturing Group (KMG) in 1998, integrating the expertise of several companies.

## **Acquisitions and Diversification:**

By 1999, KMG diversified into civil and road safety products and acquired Dewey Waters and Nicholson Plastics, doubling its size. In 2002, KMG entered the environmental sector, expanding into sewage treatment across Europe. Further acquisitions, such as AC Plastic Industries and Fibreglass Supplies, solidified KMG's position as a leading GRP water tank manufacturer.

## **Rebranding to Tricel:**

In 2014, KMG rebranded as Tricel, uniting all companies under one identity. Tricel continued to expand, creating new jobs, acquiring Puraflo and Finol Oils in 2015, and entering the French market with the Tricel sewage treatment system.

## **Innovations and Sustainability:**

Recent years saw investments in robotics and automated production processes, alongside a strong focus on sustainability. In 2021, Tricel installed Ireland's largest combined Heat Pump and Solar PV system, reducing CO2 emissions by 357,800 kg per year and significantly cutting oil dependency.





# We operate across 19 Locations in Europe

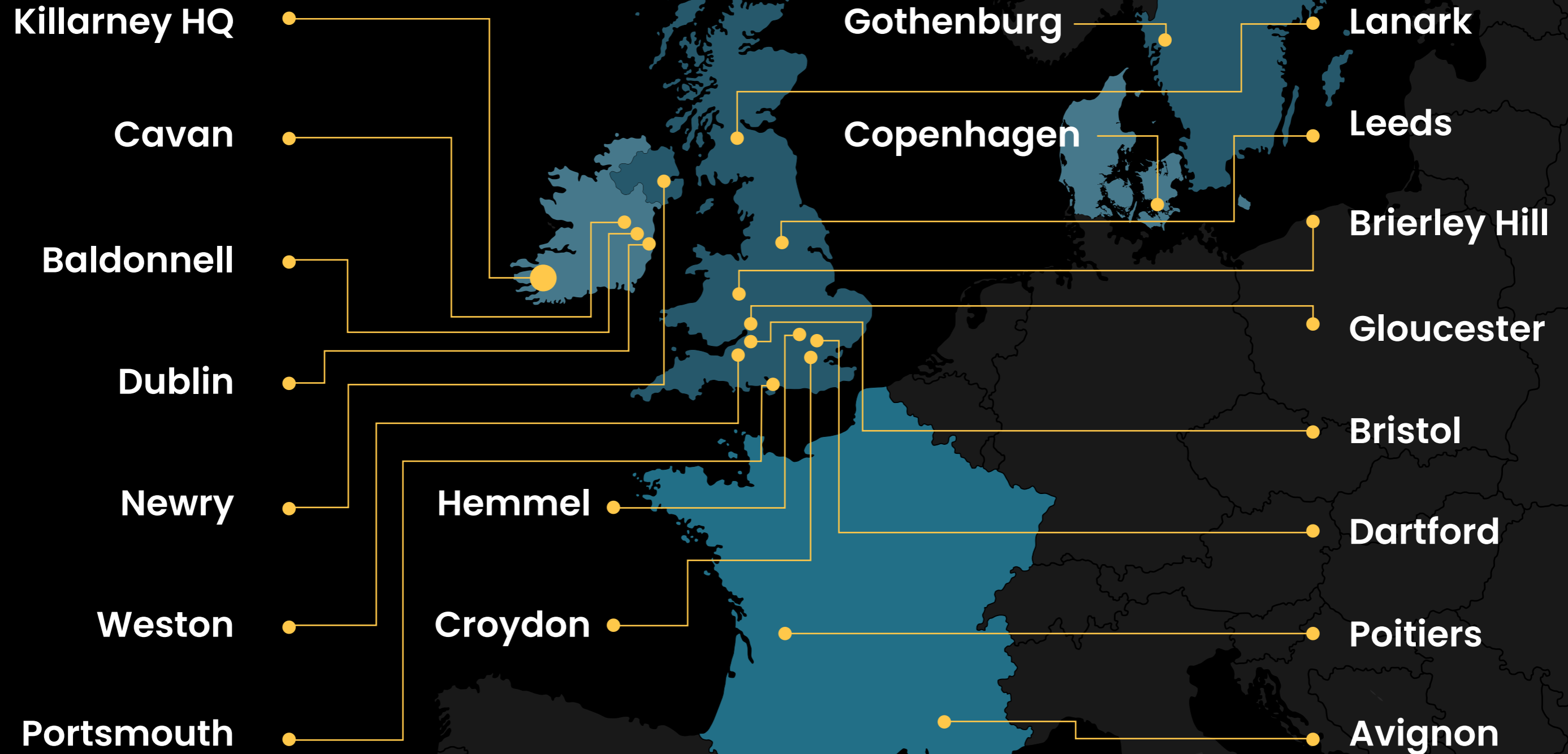

“

Tricel has the capacity for manufacturing and distribution which enables us to offer our GRP cold water tanks across the UK and for export markets.

Our expertise lies in the manufacture of Regulation 4 (1)a Approved GRP sectional tanks with capacities ranging from 1,000 to 2,000,000 litres, as well as one piece tanks spanning from 45 to 16,000 litres.

We offer a versatile selection, including both standard models and bespoke tanks designed to meet the unique requirements of any water storage project.

”

## OUR ACCREDITATIONS



# STANDARD ONE PIECE TANK RANGE.



## Why Purchase a Standard GRP One Piece Water Storage Tank?

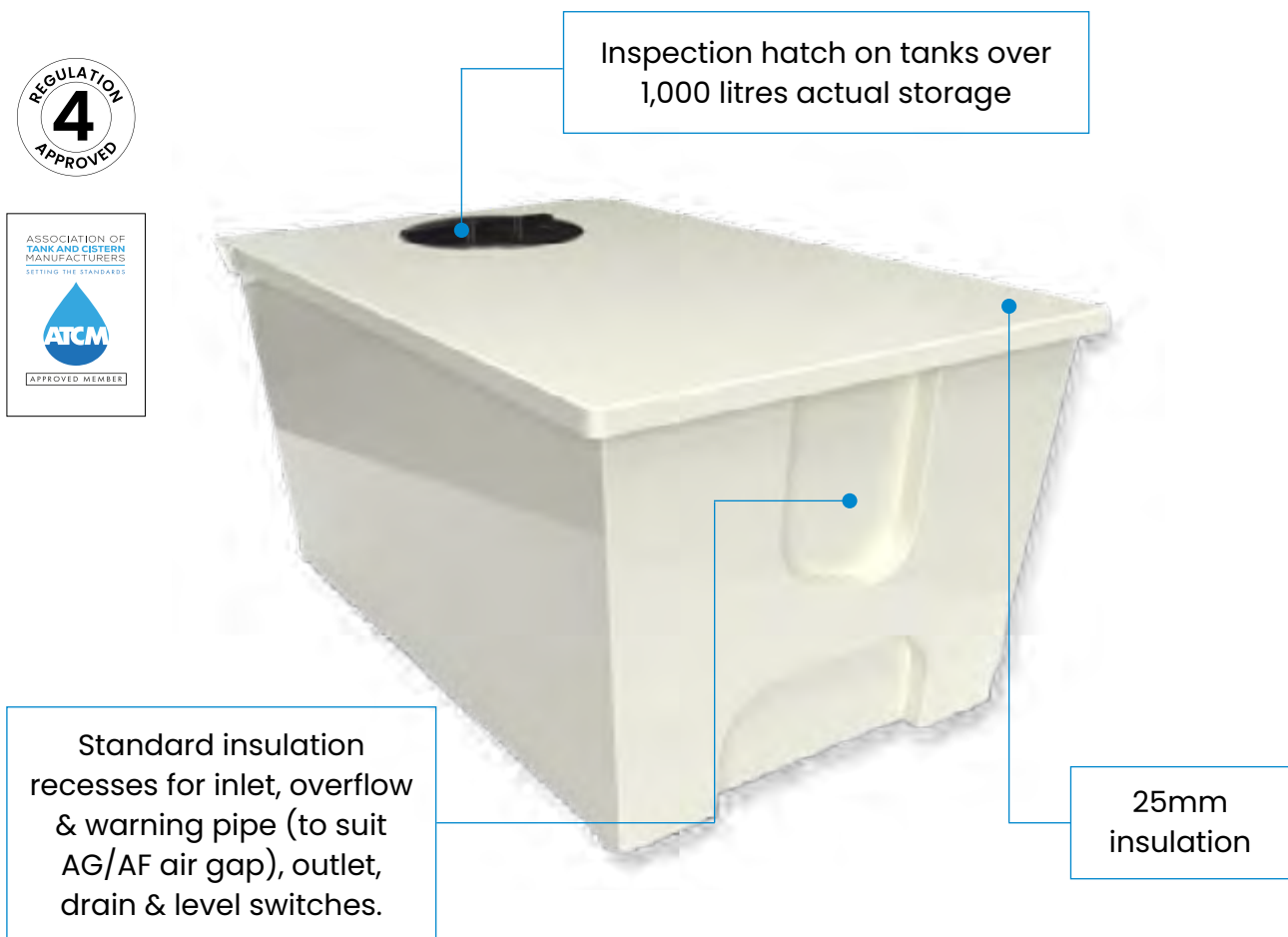

- Nationwide next day delivery on selected stock models (subject to availability)
- Long life corrosion free design
- Suitable for internal or external applications
- Full range of connections/ancillary items available
- Close fitted sealed lid
- Technical advice on all water storage projects
- Excellent after-sales-service as standard

# STANDARD ONE PIECE TANK RANGE.

## STANDARD OPTIONS

## BESPOKE OPTIONS

Tank Model	External Dimensions (L x W x H)	Internal Dimensions (L x W x H)	Nominal Capacity (Litres)	Reinforced Base (as Standard)	Available as Two Piece Tank	Available with Raised Float Valve	Option for Division
TW45	495 x 370 x 345mm	455 x 330 x 335mm	45	X	X	X	X
TW70	532 x 380 x 537mm	455 x 300 x 455mm	70	X*	X	X	X
TW100	770 x 460 x 490mm	655 x 350 x 450mm	100	X*	X	X	X
TW150	785 x 660 x 490mm	655 x 535 x 450mm	150	X*	X	✓	X
TW180	700 x 575 x 575mm	625 x 490 x 560mm	182	X*	X	X	X
TW225	1200 x 535 x 480mm	1100 x 435 x 465mm	227	X*	X	X	X
TW250	785 x 660 x 775mm	670 x 545 x 735mm	250	X*	X	✓	X
TW315	1240 x 585 x 585mm	1150 x 495 x 575mm	318	X*	X	X	X
TW450	1448 x 737 x 599mm	1310 x 600 x 580mm	454	X*	X	✓	X
TW500	1130 x 755 x 840mm	1020 x 625 x 800mm	500	X*	✓	✓	X
TW560	1290 x 1065 x 615mm	1125 x 895 x 575mm	560	X*	X	✓	X
TW700	1645 x 1035 x 590mm	1485 x 870 x 550mm	700	X*	X	✓	X
TW800	1290 x 1065 x 885mm	1130 x 900 x 845mm	800	X*	✓	✓	X
TW970	1285 x 1000 x 965mm	1175 x 900 x 885mm	970	X*	✓	✓	X
TW1000	1180 x 1180 x 1040mm	1030 x 1030 x 1000mm	1000	X*	✓	✓	X
TW1250	1180 x 1180 x 1290mm	1000 x 1000 x 1250mm	1250	X*	✓	✓	X
TW1350	1800 x 1470 x 790mm	1585 x 1190 x 715mm	1350	X*	X	✓	✓
TW1500	1685 x 1185 x 1040mm	1530 x 1030 x 1000 mm	1500	X*	✓	✓	✓
TW1500H	1180 x 1180 x 1540mm	1030 x 1030 x 1500mm	1500	X*	✓	✓	X
TW2000	2185 x 1185 x 1040mm	2030 x 1030 x 1000mm	2000	X*	✓	✓	✓
TW2250	1680 x 1180 x 1560mm	1500 x 1000 x 1500mm	2250	✓	✓	✓	✓
TW2700	2030 x 1500 x 1290mm	1850 x 1250 x 1220mm	2700	✓	✓	✓	✓
TW3000	2180 x 1180 x 1560mm	2000 x 1000 x 1500mm	3000	✓	✓	✓	✓
TW3230	2870 x 1420 x 1050mm	2670 x 1220 x 990mm	3230	✓	✓	✓	✓

\*(Available as Option)



**STANDARD  
OPTIONS**

**BESPOKE  
OPTIONS**

Tank Model	External Dimensions (L x W x H)	Internal Dimensions (L x W x H)	Nominal Capacity (Litres)	Reinforced Base (as Standard)	Available as Two Piece Tank	Available with Raised Float Valve	Option for Division
TW3600	2680 x 1830 x 1010mm	2500 x 1575 x 950mm	3600	✓	✓	✓	✓
TW4000	2200 x 2200 x 1060mm	2000 x 2000 x 1000mm	4000	✓	✓	✓	✓
TW4500	2680 x 1830 x 1260mm	2500 x 1575 x 1200mm	4500	✓	✓	✓	✓
TW6000	2200 x 2200 x 1560mm	2000 x 2000 x 1500mm	6000	✓	✓	✓	✓
TW8000H	2200 x 2200 x 2060mm	2000 x 2000 x 2000mm	8000	✓	✓	✓	✓
TW9000	3200 x 2200 x 1560mm	3000 x 2000 x 1500mm	9000	✓	✗	✓	✓
TW12000	3200 x 2200 x 2060mm	3000 x 2000 x 2000mm	12000	✓	✗	✓	✓

\*(Available as Option)

- Manufactured in accordance with BS EN13280 and BS EN13121, the Water Supply (Water Fittings) Regulations 1999 and Regulation 4 approved for use with wholesome water.
- Our products are manufactured under the ISO 9001:2015 Quality Management System, with specific quality control arrangements being based upon BS4549-1 (reinforced plastic mouldings).
- The raw materials of the GRP shall conform as appropriate to BS 3532, resin systems and BS EN14020, E glass rovings.
- Internal isophthalic gelcoat surface on all tanks which is impervious to water and resistant to bacterial growth.
- All tanks are fitted with a cover to exclude light and prevent the ingress of particles and insects.
- The encapsulated insulation used has an Ozone Depletion Potential of zero and Global Warming Potential of less than five and is HCFC & CFC free.
- Our standard 25mm thick insulation has a thermal conductivity value of 0.042 w/m2 Deg C.

# STANDARD TWO PIECE TANK RANGE.

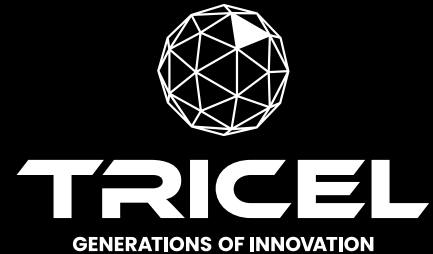

## The cost effective storage solutions



### Benefits of a Two Piece Tank:

- Ideal for restricted access.
- Easily & quickly assembled.
- Can be left in place or alternatively can be dismantled & re-used for another application.
- Virtually zero maintenance.
- Full range of connections & ancillary items.
- Efficiency of assembly is beneficial in emergency situations.
- Cost effective storage solutions.
- Fast delivery.

### Two Piece Tank Specifications:

- All materials used approved by REG4
- Manufactured in accordance with bs en 13280 (potable & non-potable water regulations)
- Full iso 9001:2015 quality management system certification
- Standard tank colour is cream ral 9001; we can supply in any bs or ral colour to suit your requirements
- Insulated and uninsulated tanks available
- Insulation is encapsulated, hcfc & cfc free
- Comply with all relevant british standards & water regulations
- All supplied within the scope of our bs en iso 9902:1994 quality assurance registration

### Two Piece GRP Water Tank Sizing:

- Standard capacities available from 500 litres to in excess of 8000 litres.
- Full size listing on reverse. If you cannot find your preferred size, contact our technical sales team about our bespoke options today!



# CUBE TIF TANKS.



## Features and benefits of the self-assembly Cold water storage tank:

- Self-assembly
- Easy access for restricted spaces
- Can be pushed up against a wall on three sides
- Easy to transport one pallet
- Competitive lead times
- Regulation 4 approved
- Ideal to sit above or beside booster set
- Can sit on a solid flat base or steel frame
- Standard inlet and outlet recesses
- No drawing mark up needed



## Easy access for restricted spaces including:

- Basement plant rooms
- Roof installations
- Attic spaces



**TO DISCUSS YOUR PROJECT REQUIREMENTS,  
CONTACT US TODAY!**

# STANDARD CUBE TIF TANK RANGE.

## Specifications

- All materials used approved by wras (water regulations advisory scheme)
- Manufactured in accordance with bs en13280 (potable & non-potable water regulations)
- Isophthalic resin applied for potable water tanks which reduces bacterial growth
- Full iso 9001:2015 quality management system certification
- Standard tank colour is cream ral 9001; we can supply in any BS or RAL colour to suit your requirements
- Insulated and uninsulated tanks available
- Insulation is encapsulated, hcfc & cfc free

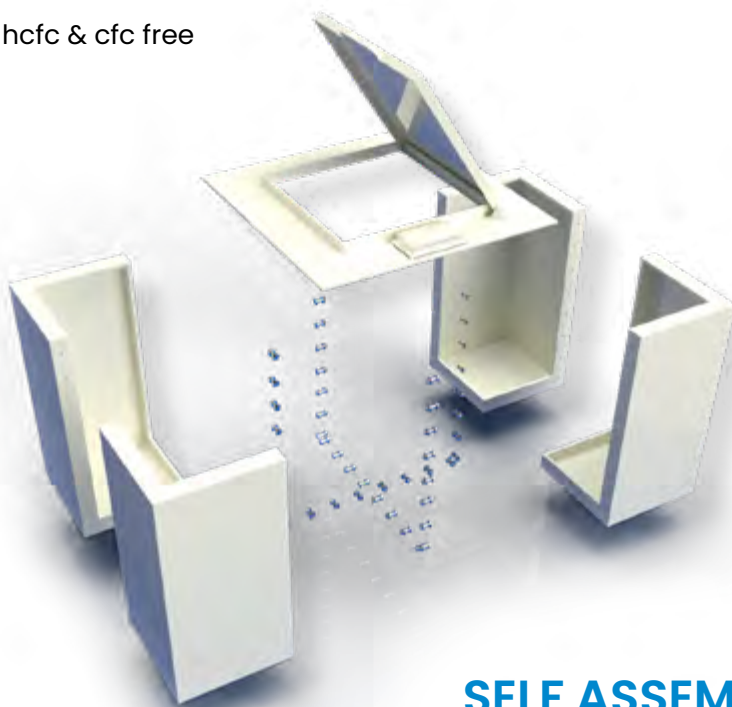

**SELF ASSEMBLY!**

**WE PROVIDE BESPOKE TANKS IDEAL FOR A RANGE OF INDUSTRIES FROM DOMESTIC TO COMMERCIAL**



COMMERCIAL  
& RESIDENTIAL



HEALTH &  
EDUCATION



MANUFACTURING  
& INDUSTRIAL



HOTEL &  
LEISURE



FIRE  
SUPPRESSION



RETAIL AND  
SHOPPING CENTRES

# GRP SECTIONAL COMBINED TANK & PUMP STATION.



## Product Description

GRP Hot Press Sectional CTPS are a tidy, cost effective solution for water storage. Manufactured from GRP making it a durable lifelong station which includes a practical working space for water tank ancillaries including water pumps & electrical equipment, these stations are suitable for both internal and external applications.



## Benefits Include:

- Very compact
- Professional station
- High strength
- Low maintenance
- Speedy assembly on site Saving on cost and space, two products direct from one supplier
- Long life materials
- Tank ancillaries available
- Light weight, 1/10 weight of concrete & steel
- Suited to individual or repeat projects
- Ease of handling, installation and transportation
- Deliverable on pallets; negates the requirement for a HI-AB
- GRP material



# GRP SECTIONAL TANK AND COMBINED ENCLOSURE OPTIONS

## INTERNALLY FLANGED BASE

### Enclosure Dimensions

- Tank length is variable depending upon capacity required.
- Housing length (Length is unrestricted)

The GRP tanks are primarily available with internally flanged bases but can come with ext flanged bases if required. We offer a full project management service from initial design to final installation. All our tanks are Regulation 4 approved.



## COMBINED ENCLOSURE TECHNICAL DRAWINGS

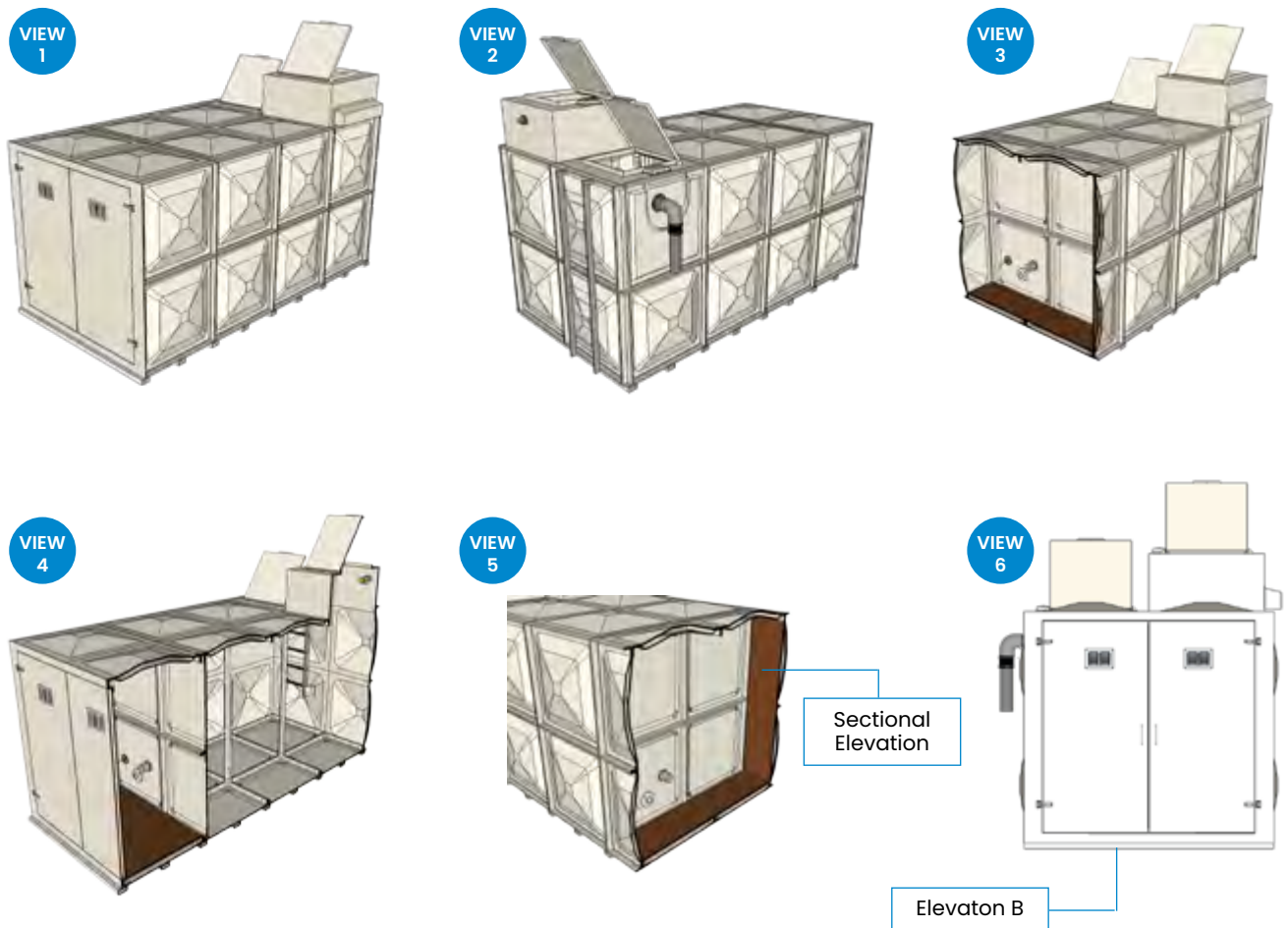

# ONE PIECE COMBINED TANK & PUMP STATION.

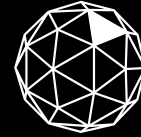

**TRICEL**  
GENERATIONS OF INNOVATION

## Product Description

GRP One Piece Combined Tank and Pump Stations are a tidy, cost effective solution for water storage. Manufactured from GRP making it a durable lifelong enclosure which includes a practical working space for water tank ancillaries including water pumps & electrical equipment, these stations are suitable for both internal and external applications.



## Benefits Include:

- Very compact
- Professional station
- Light weight, 1/10 weight of concrete & steel
- High strength
- Corrosion resistant
- Ease of handling, installation and transportation
- Can be lifted into place in one go
- No on site assembly required
- Saving on cost and space, two products direct from one supplier
- Low maintenance
- Long life materials
- Tank ancillaries available
- Suited to individual or Repeat projects
- GRP material



# ONE PIECE COMBINED TANK AND PUMP STATION.

MODEL	CAPACITY	EXTERNAL DIMENSIONS (mm)		
	Nominal (Itrs)	Length	Width	Height
CTPS1500	1500	1990	1240	2095
CTPS2000	2000	2240	1240	2095
CTPS2500	2500	2490	1240	2095
CTPS3000	3000	2740	1240	2095
CTPS3500	3500	2990	1240	2095
CTPS4000	4000	2240	2240	2079
CTPS6000	6000	2740	2240	2079
CTPS8000	8000	3240	2240	2079
CTPS10000	10000	3740	2240	2079
CTPS12000	12000	4240	2240	2079
CTPS14000	14000	4740	2240	2079
CTPS16000	16000	5240	2240	2079



**SCAN ME**  
Explore this model  
online and discover  
in Augmented  
Reality on your  
mobile device.



CTPS 2500L



# LPCB TANKS

# AVAILABLE INLET VALVES & ASSOCIATED FLOW RATES



**TRICEL**  
GENERATIONS OF INNOVATION

Refill rates for full capacity tanks in BS EN 12845 states that 'The water source shall be capable of refilling the tank in no more than 36 hours'. In order to assist you with selecting the most suitable inlet valve for your application, please see below the available inlet valve flow rate chart for use in our LPS 1276 Issue 2.0 accredited tanks:

Supply Pressure		FLOW RATE & SIZE SELECTION – LITRES/SECTIONS									
		Size & Type									
BAR	Psi	1/2"	3/4"	1"	1 1/4"	1 1/2"	2"	2 1/2"	3"	4"	
		Pegler 901 Equilibrium	Pegler 901 Equilibrium	Keraflo FB25 (LPS2083)	Pegler 901 Equilibrium	Pegler 901 Equilibrium	Keraflo FB50SF (LPS2083)	Pegler 901 Equilibrium	Keraflo FB80 (LPS2083)	Pegler 901 Equilibrium	
		l/s	l/s	l/s	l/s	l/s	l/s	l/s	l/s	l/s	
0.5	7.3	0.5	0.9	0.18	3.5	4.2	0.67	8	1.34	24	
1	15	0.8	1.2	0.79	4.8	5.8	3	11.2	6	31.7	
1.5	21.8	1	1.5	0.97	5.9	7.3	3.68	13.3	7.35	37.3	
2	29	1.1	1.7	1.12	6.8	8.2	4.25	15.3	8.49	41.7	
2.5	36.3	1.2	1.8	-	7.5	9.2	-	17	-	45.7	
3	43.5	1.3	2	1.38	8.2	10	5.2	18.3	10.4	48.8	
4	58	1.5	2.2	1.59	9.3	11.3	6	20.8	12.01	55	
5	72.5	1.6	2.5	1.78	10.3	12.8	6.71	23	13.43	60	
6	87	1.7	2.7	-	11.3	13.9	-	25	-	65	
7	101.5	1.8	2.8	-	12	15.2	-	26.5	-	69.8	
8	116	1.9	3	-	12.8	16.3	-	27.9	-	73.3	
9	130.5	2	3.1	-	13.5	17.3	-	29.2	-	77.5	
10	145	2.1	3.3	-	14.2	19.8	-	30.3	-	81.3	

Notes: The flow rates quoted will only occur when each float valve is fully open and in the case of the Pegler valves, will reduce as the water in the tank rises. Excessive or unequal pipe runs to each float valve will result in lower running pressure and reduced flow rates.

# GRP SECTIONAL

# Cold Water Storage Tanks.



**TRICEL**  
GENERATIONS OF INNOVATION

Sectional tanks are supplied in the following formats:

**Internally flanged base (IFB) - Externally flanged sides:**

This tank is suitable for installation on a fully supporting flat base.

**Externally flanged base (EFB) - Externally flanged sides:**

This type of base allows easy access to bolts for maintenance and tank may be fully drained.

**Totally Internally Flanged (TIF):**

This tank is used where the space available is restricted.

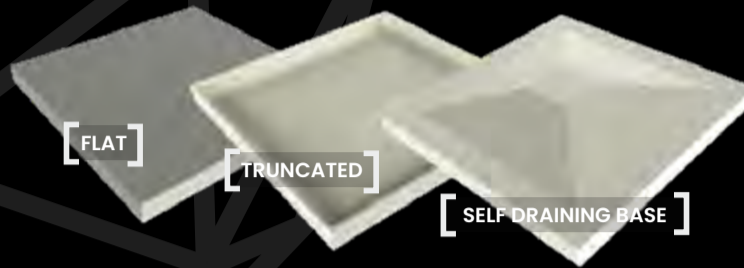

**Panel Variants**

Our experience along with architects/designers demands have led our engineering team to design and manufacture a series of panels, to give more flexibility to our clients.

Tank Range - We manufacture the following range of cold water Storage tanks:

- Standard Sectional Cold Water Storage Tanks
- L Shaped Sectional Cold Water Storage Tanks
- Totally Internally Flanged Tanks

All of which are Regulation 4 Approved.



**GRP Sectional Cold Water Storage Tanks (Standard & L Shaped)**

Tricel Water employs two moulding techniques Single Face Contact Moulding (SFCM) and Hot Press Moulding (HPM) to manufacture the sectional panels.

The method employed depends on individual site requirements and which technique provides the most economical solution for our clients.

Both techniques adhere to current British Standards, are Regulation 4 Approved and covered by our quality control procedures.

**Hot Press Tank Panel Configuration**

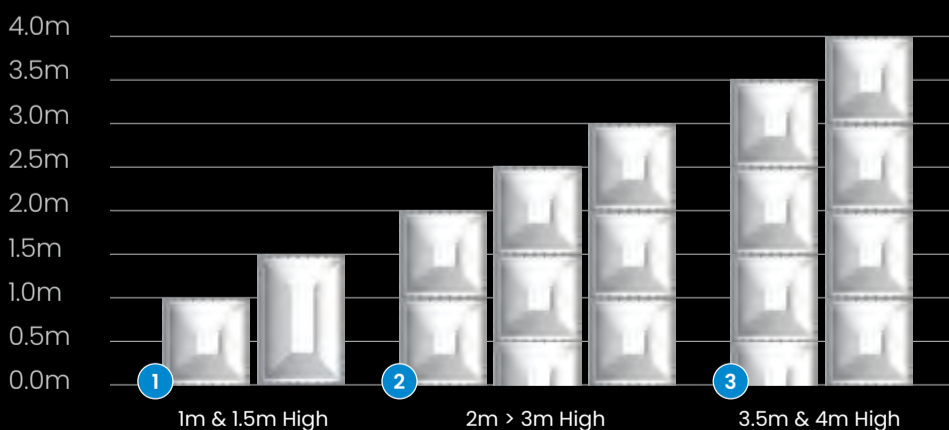

Hot Press Sectional Tank (IFB) (EFB)	Tif Tank (TIF)
Twin Compartment options available to provide continuous supply during maintenance periods.	Twin Compartment options available to provide continuous supply during maintenance periods.
Pressed SMC (Sheet Moulding Compound) panels with UV stabilised properties.	UV stabilised external gelcoat finish.
High strength isophthalic resin with improved resistance to bacterial growth.	Internal isophthalic gelcoat surface to prevent bacterial growth.
Manufactured in accordance with BS EN13280:2011.	Manufactured in accordance with BS 13280:2011.
HCFC & CFC free encapsulated Insulation: 38mm - 0.57 w/m2 Deg C 50mm - 0.40 w/m2 Deg C	HCFC & CFC free encapsulated Insulation: 25mm - 0.85 w/m2 Deg C 50mm - 0.40 w/m2 Deg C
Internally & Externally Flanged base options  Available both laterally and vertically in metric 1m & 500mm increments up to 4m high. L shaped tanks up to 3m high.	Ideal for restricted plantroom space: Available in lateral panel increments of 250mm, 500mm, 750mm & 1m. Standard 500mm and custom 100mm increments up to 3m high.
	Self-draining Externally Flanged Base available.
Regulation 4 Approved up to 2,000,000 Litres.	Regulation 4 Approved up to 500,000 litres.



**Totally Internally Flanged Tanks (Standard & L Shaped)**

Where space restrictions apply the Tricel TIF tank is the best storage option to allow you to maximise storage capacity.

Standard access requirements request a clearance of 500mm around the tank for assembly and maintenance purposes. With the Tricel TIF design, these access requirements are reduced.

These tanks are designed, so that they can be constructed from within, requiring less space for assembly. The tank may be positioned up against a wall or column, leaving space for other equipment within the plant room.

**TIF Tank Panel Configuration**

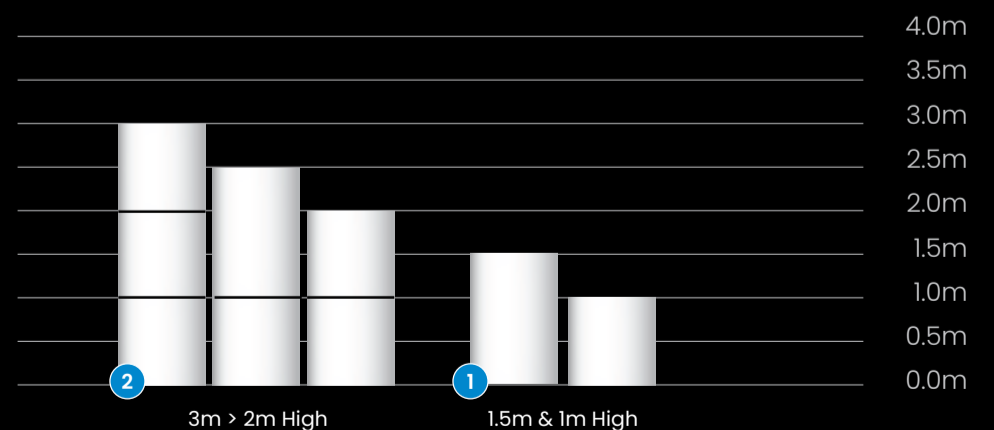

**WATER STORAGE SPECIALISTS**

**TRICEL LANARK**

Riverside Road, Kirkfieldbank, Lanark, ML11 9JS, United Kingdom.  
T: +44 (0) 1934 421 477  
E: sales@tricelwater.co.uk

**TRICEL WESTON**

Winterstoke Road, Weston-super-Mare, BS24 9AN, United Kingdom.  
T: +44 (0) 1934 421 477  
E: sales@tricelwater.co.uk

**TRICEL CROYDON**

10 Tait Road, Croydon, CR0 2DP, United Kingdom  
T: +44 (0) 1934 421 477  
E: sales@tricelwater.co.uk

**PUMPING SOLUTIONS**

**TRICEL PORTSMOUTH**

Unit 14, Arnside Road, Waterlooville, Hampshire, PO7 7UP, United Kingdom  
T: +44 (0) 196 258 7244  
E: websales@tricelpumps.co.uk

# HOT PRESS, INTERNALLY FLANGED (IF).



**Ideal for limited space applications and improves capacity. Available up to 2m high.**

## Tank Support & Clearance Requirements

A Internally Flanged tank can be placed directly on to a continuous flat surface e.g. plinth or tank room floor providing that the surface does not vary more than 2mm in any 1m or a total of 6mm in any 6m, measured laterally or diagonally.

The completed base structure shall be capable of supporting the weight of the tank and its maximum water load i.e. filled to the brim, along with any potential wind or snow loads as applicable.

If foundations are to be provided by suspended floors or beams, then the foundation should be constructed so that when the tank is full, the combined deflections should not exceed 1/500th of the span (BS EN 13280:2001).

Alternatively, if the plinth tolerance cannot be achieved, the use of levelling steels will allow you to take up any irregularities with shims up to a maximum of 18mm. Our standard levelling steels are 100mm x 50mm high galvanised box section and must be fully supported (non-spanning) and positioned at 500mm centres.

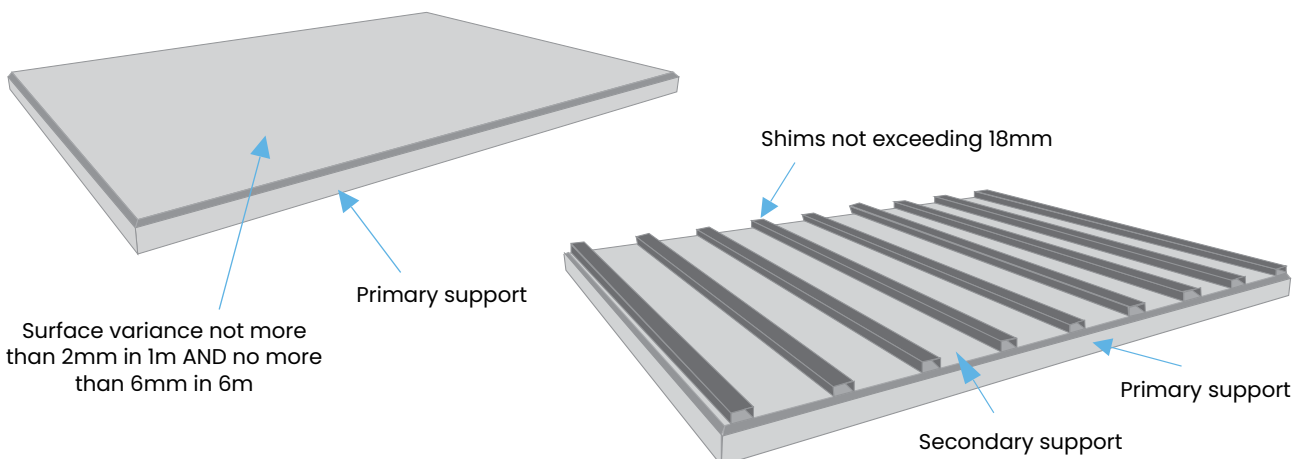

# CLEARANCE REQUIREMENTS.

## For Installation and future maintenance

This style of tank is ideal where space is limited and can be pushed within 50mm of a wall.

The minimum clearance requirements taken from the external measurements of the tank are 50mm on 3 sides, minimum 500mm (\*1000mm when fitted with a hooped ladder) on the 4th side to accommodate pipework and 750mm headroom clearance for safe access (\*\*1200mm when fitted with Guardrail)

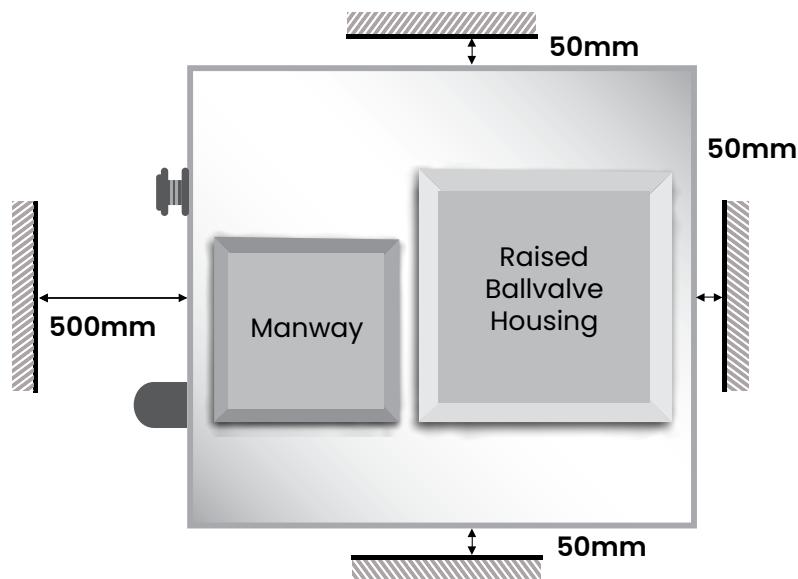

Plan view of tank with clearance measurements

# HOT PRESS, INTERNALLY FLANGED BASE (IFB).



**Our most popular and cost effective option. Available up to 4m high. (Once adequate space is available)**

## Tank Support & Clearance Requirements

An internally flanged base tank can be placed directly on to a continuous flat surface e.g. plinth or tank room floor providing that the surface does not vary more than 2mm in any 1m or a total of 6mm in any 6m, measured laterally or diagonally.

The completed base structure shall be capable of supporting the weight of the tank and its maximum water load i.e. filled to the brim, along with any potential wind or snow loads as applicable. If foundations are to be provided by suspended floors or beams, then the foundation should be constructed so that when the tank is full, the combined deflections should not exceed 1/500th of the span (BS EN 13280:2001).

Alternatively, if the plinth tolerance cannot be achieved, the use of levelling steels will allow you to take up any irregularities with shims up to a maximum of 18mm. Our standard levelling steels are 100mm x 50mm high galvanised box section and must be fully supported (non-spanning) and positioned at 500mm centres.

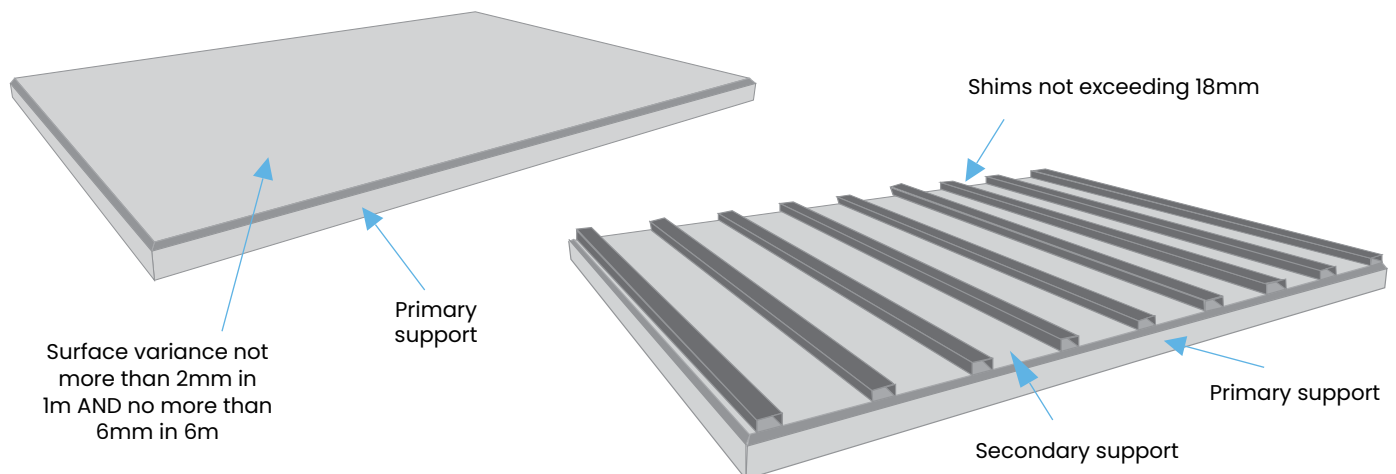

# CLEARANCE REQUIREMENTS.

## For Installation and future maintenance

This style of tank is not suitable for pushing up against a wall, or where there is restricted space or headroom. Listed below are the minimum clearance requirements taken from the internal measurements of the tank:

TANK HEIGHT	CLEARANCE REQUIREMENT
3.5m & 4m	1000mm clearance on all sides
2.5m & 3m	800mm clearance on all sides*
1m > 2m	500mm clearance on all sides*

- 1m > 2m = 500mm\* perimeter clearance and 750mm\*\* headroom clearance for safe access.
- 2.5 & 3m = 800mm\* perimeter clearance and 750mm\*\* headroom clearance for safe access.
- 3.5m & 4m = 1000mm perimeter clearance and 750mm\*\* headroom clearance for safe access.

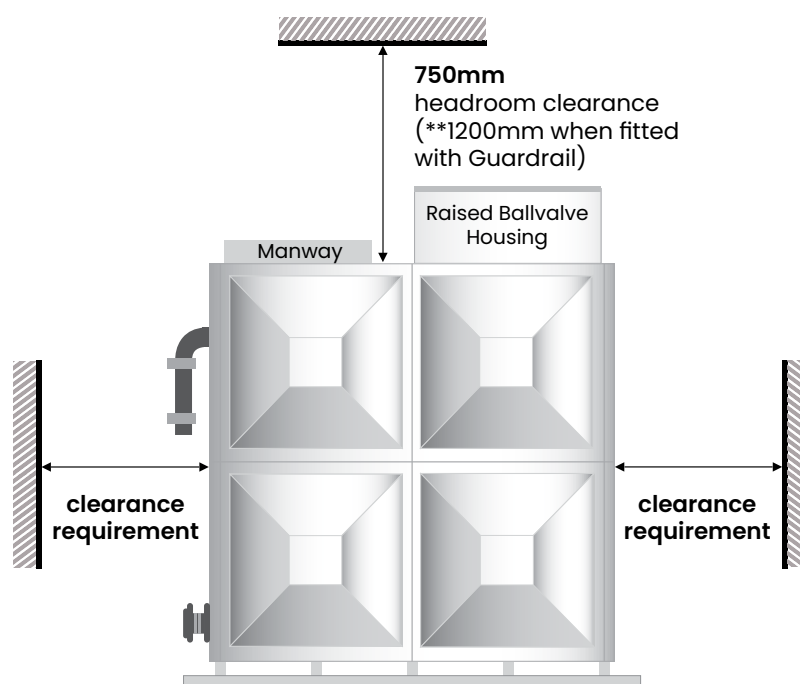

Profile view of typical 2m high tank

# TOTALLY INTERNALLY FLANGED (TIF).



**Handmade, bespoke solutions for tight spaces. Available up to 3m high.**

## Tank Support & Clearance Requirements

A Totally Internally Flanged tank can be placed directly on to a continuous flat surface e.g. plinth or tank room floor providing that the surface does not vary more than 2mm in any 1m or a total of 6mm in any 6m, measured laterally or diagonally. The completed base structure shall be capable of supporting the weight of the tank and its maximum water load i.e. filled to the brim, along with any potential wind or snow loads as applicable. If foundations are to be provided by suspended floors or beams, then the foundation should be constructed so that when the tank is full, the combined deflections should not exceed 1/500th of the span (BS EN 13280:2001).



Alternatively, if the plinth tolerance cannot be achieved, the use of levelling steels will allow you to take up any irregularities with shims up to a maximum of 18mm. Our standard levelling steels are 100mm x 50mm high galvanised box section and must be fully supported (non-spanning) and positioned at 500mm centres.

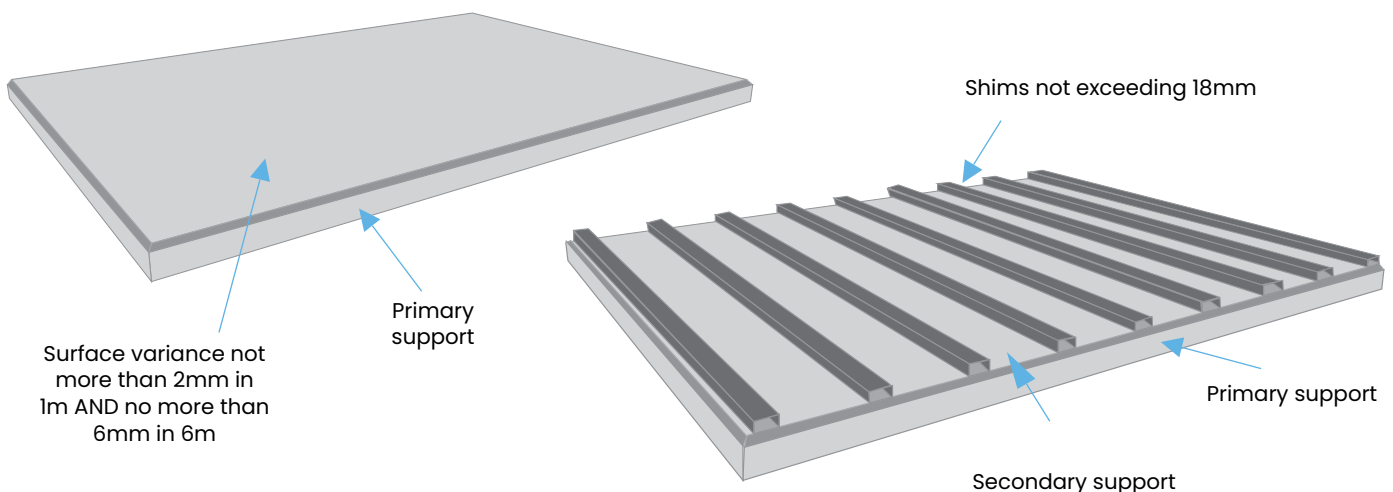

# CLEARANCE REQUIREMENTS.

## For Installation and future maintenance

This style of tank is ideal where space is limited and can be pushed within 50mm of a wall. The minimum clearance requirements taken from the external measurements of the tank are 50mm on 3 sides, minimum 500mm (\*1000mm when fitted with a hooped ladder) on the 4th side to accommodate pipework and 750mm headroom clearance for safe access (\*\*1200mm when fitted with Guardrail).

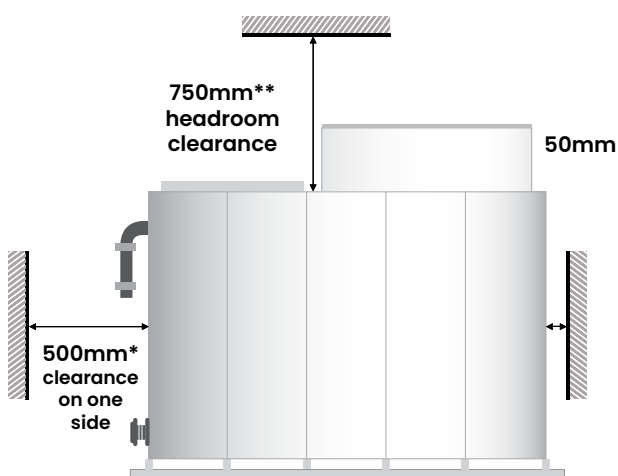

Plan view of tank with clearance measurements

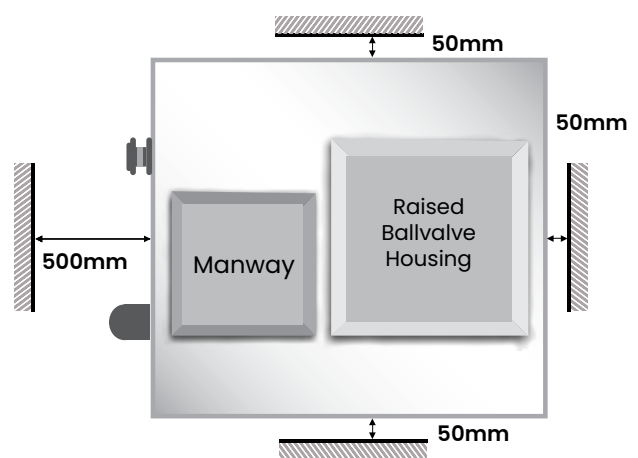

Plan view of tank with clearance measurements

# TIF CASE STUDY



## Benefits of totally Internally Flanged (TIF) tanks in TIF developments:

- Less space required – space saving
- (Installed at wall or corner)
- Maximise floor space
- Access restrictions
- Palletised easy to deliver
- Quick assembly timelines
- Any volume of water
- Fully customisable to space available (l/w/h)
- Customisable shape configurations (t-shape, l-shape)
- Insulated and non-insulated options
- Ideal for replacing tanks during building refurbishments when space is tight



## Ideal for Installation in restricted spaces, including:

- Basement plant rooms
- Roof installations
- Attic spaces



**WE PROVIDE BESPOKE TANKS IDEAL FOR A RANGE OF INDUSTRIES FROM DOMESTIC TO COMMERCIAL**



COMMERCIAL  
& RESIDENTIAL



HEALTH &  
EDUCATION



MANUFACTURING  
& INDUSTRIAL



HOTEL &  
LEISURE



FIRE  
SUPPRESSION



RETAIL AND  
SHOPPING CENTRES

# TIF INSTALLATIONS.

## TIF HOTEL WATER TANK INSTALLATION

**Location:** Four Seasons Hotel at Park Lane, London

**Tank Size:** 2.5m x 1.5m x 1m

**Solution:** Hand Lay Up (HLU) Totally Internally Flanged Tank

This tank is placed in an alcove archway under the pavement in London city centre.. Pedestrians walk over the top of it every day without realising it. Space restriction was a major factor in this project. The space allocated for the water storage tank was minimal, and the hotel needed to store as much potable water as possible.

To capitalise on the space allocated, we designed and manufactured a HLU totally internally flanged tank that could be placed against three walls. As all of the tank bolts are internal, access to the tank was only needed on one side.



## TIF HOUSING COMPLEX – EDINBURGH

**Location:** Edinburgh

**Tank Size:** 1.7m x 0.7m x 1.7m

**CapaTIF:** 1770 litres

The existing tank was positioned in a tight space within the roof. The customer required a tank of similar size and had no other option to locate the tank anywhere else in the building. Our new tank measured 1.7m L x 0.7m W x 1.7m H and had a nominal capaTIF of 1,770 litres. The tank was assembled against three walls, the design allowed 500mm of space above the tank for future maintenance and adequate crossflow. The client thought it couldn't be done but our specialists designed a very similar sized TIF Tank to fit neatly into that space. Our highly trained install crew built the tank within this very restricted area and manoeuvred all required panelling through a narrow access hatch.



*"We've worked closely with Tricel over the last seven years. We find that Tricel can react quickly to any quote/site requests we may have and due to the type of projects we work on, Tricel's problem solving and tank expertise has helped us get it right first time. We would recommend Tricel to any company looking for help with any type of tank installation. Particularly if you are tight for space, their TIF Tanks are the perfect solution. – Mike Anderson, Director at Anderson Floor Warming".*

Contact us today at: [sales@tricelwater.co.uk](mailto:sales@tricelwater.co.uk) or [tricelwater.co.uk](http://tricelwater.co.uk)

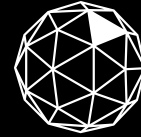

## TOTALLY INTERNALLY FLANGED (TIF) C/W SELF-DRAINING EXTERNALLY FLANGED BASE.

### Tank Support & Clearance Requirements

An Externally Flanged Base tank must be placed on either support walls, steelwork or a combination of both. The top surface of which should be flat, level and free from any local irregularities and should not vary more than 2mm in any 1m or a total of 6mm in any 6m, measured laterally or diagonally.

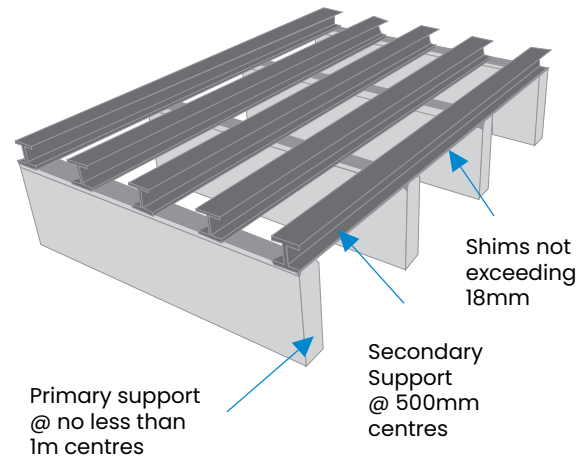

The completed base structure shall be capable of supporting the weight of the tank and its maximum water load i.e. filled to the brim, along with any potential wind or snow loads as applicable. If foundations are to be provided by suspended floors or beams, then the foundation should be constructed so that when the tank is full, the combined deflections should not exceed 1/500th of the span (BS EN 13280:2001).

Alternatively, if the pier tolerance cannot be achieved, the use of levelling steels will allow you take up any irregularities with shims up to a maximum of 18mm. Our standard levelling steels are 100mm x 50mm high galvanised box section and are non-spanning. These arrangements are only suitable for tank heights up to 2m and require pier centres of 1m.

Tanks with more than one 0.5m lateral dimension will require secondary steel supports at 500mm centres to run perpendicular to the primary supports (min 500mm high). The size of the secondary steels will depend on the spanning distance, please contact us for further guidance.

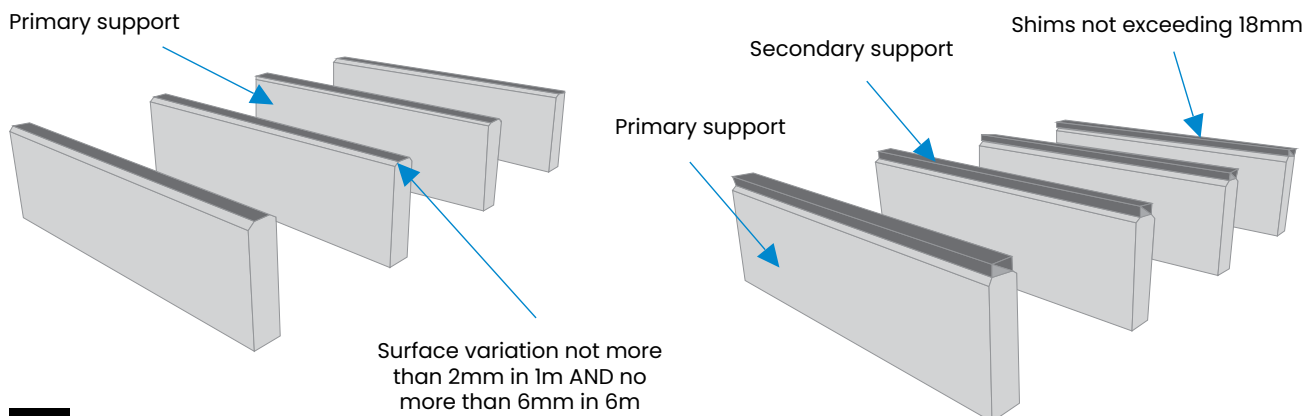

# CLEARANCE REQUIREMENTS.

## For Installation and future maintenance

This style of tank is ideal where space is limited and can be pushed within 50mm of a wall.

The minimum clearance requirements taken from the external measurements of the tank are 50mm on 3 sides, minimum 500mm (\*1000mm when fitted with a hooped ladder) on the 4th side to accommodate pipework and 750mm headroom clearance for safe access (\*\*1200mm when fitted with Guardrail).

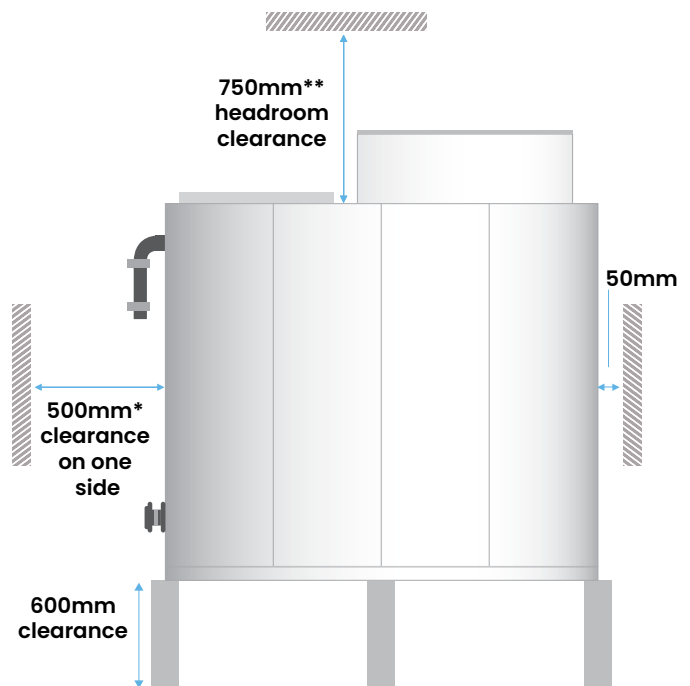

Plan view of tank with clearance measurements

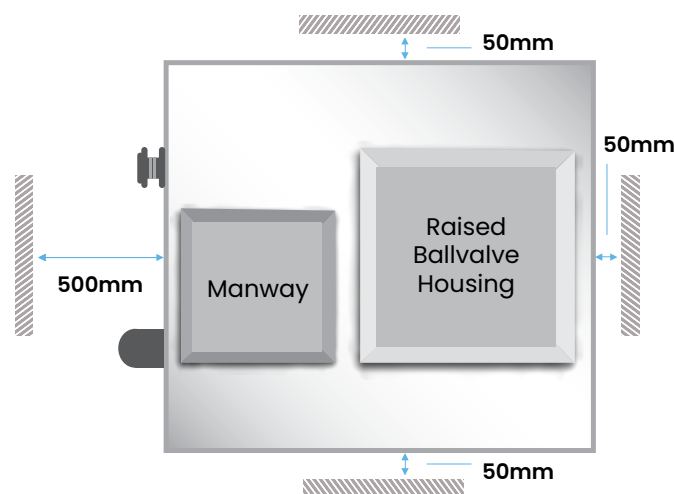

Plan view of tank with clearance measurements

## HOT PRESS – SELF – DRAINING EXTERNALLY FLANGED BASE (EFB).

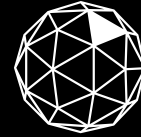

**TRICEL**  
GENERATIONS OF INNOVATION

### Tank Support & Clearance Requirements

An Externally Flanged Base tank must be placed on either support walls, steelwork or a combination of both. The top surface of which should be flat, level and free from any local irregularities and should not vary more than 2mm in any 1m or a total of 6mm in any 6m, measured laterally or diagonally.

The completed base structure shall be capable of supporting the weight of the tank and its maximum water load i.e. filled to the brim, along with any potential wind or snow loads as applicable. If foundations are to be provided by suspended floors or beams, then the foundation should be constructed so that when the tank is full, the combined deflections should not exceed 1/500th of the span (BS EN 13280:2001).ined deflections should not exceed 1/500th of the span (BS EN 13280:2001).

Alternatively, if the pier tolerance cannot be achieved, the use of levelling steels will allow you take up any irregularities with shims up to a maximum of 18mm. Our standard levelling steels are 100mm x 50mm high galvanised box section and are non-spanning. These arrangements are only suitable for tank heights up to 2m and require pier centres of 1m.

Tank heights of 2.5m > 4m will require secondary steel supports at 500mm centres that will run perpendicular to primary supports (min 500mm high). The size of the secondary steels will depend on the tank height and the spanning distance, please contact us for further guidance. This arrangement will also be a requirement for tanks with more than one 0.5m lateral dimension e.g. 2.5m x 2.5m.

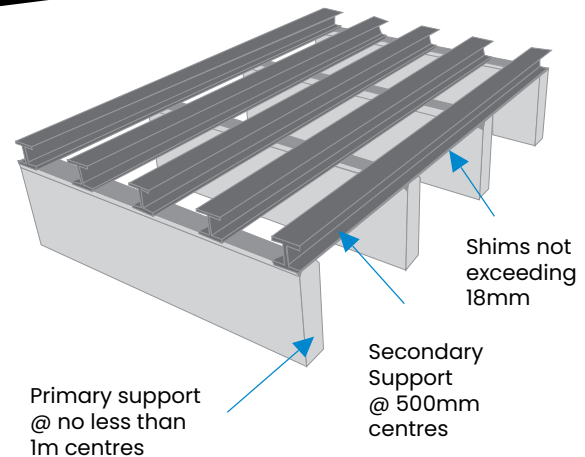

Primary support

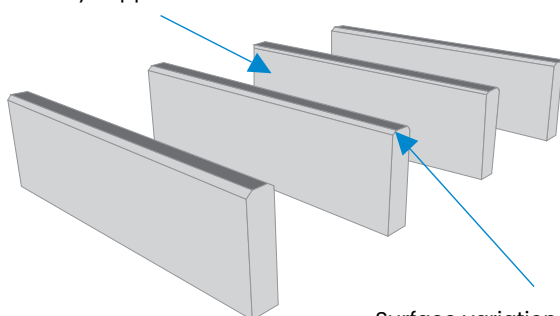

Surface variation not more than 2mm in 1m AND no more than 6mm in 6m

Secondary support Shims not exceeding 18mm

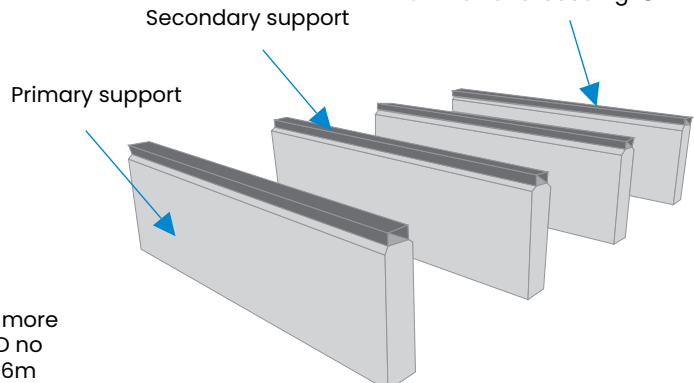

# CLEARANCE REQUIREMENTS.

## For Installation and future maintenance

This style of tank is not suitable for pushing up against a wall, or where there is restricted space or headroom. Listed below are the minimum clearance requirements taken from the internal measurements of the tank:

- 1m & 1.5m = 500mm\* perimeter clearance and 750mm\*\* headroom clearance for safe access.
- 2m > 3m = 800mm\* perimeter clearance and 750mm\*\* headroom clearance for safe access.
- 3.5m & 4m = 1000mm perimeter clearance and 750mm\*\* headroom clearance for safe access.

TANK HEIGHT	CLEARANCE REQUIREMENT
3.5m & 4m	1000mm clearance on all sides
2.5m & 3m	800mm clearance on all sides*
1m > 2m	500mm clearance on all sides*

\*1000mm required on at least one side when fitted with a hooped ladder.

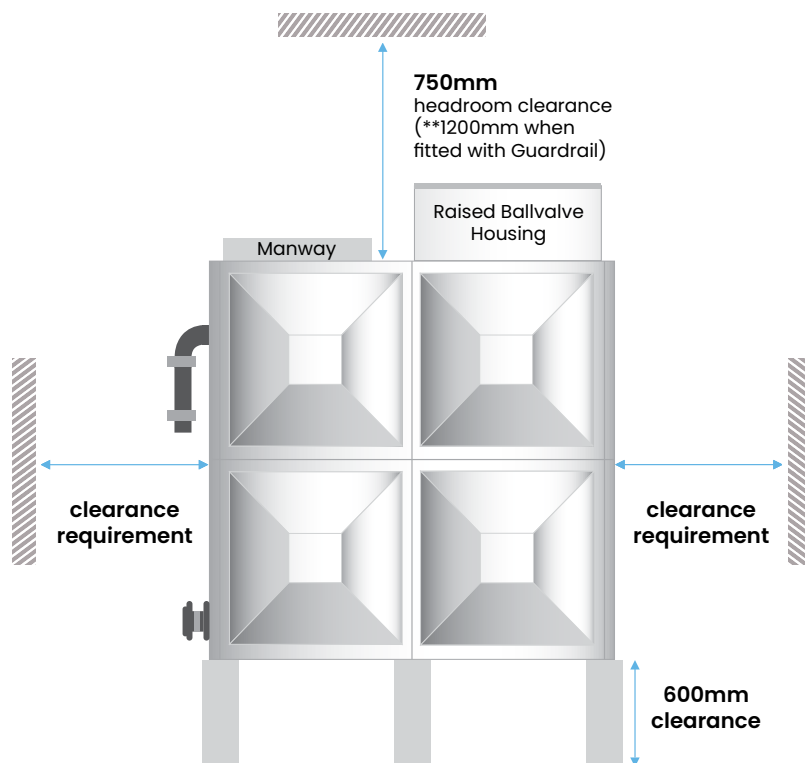

Profile view of typical 2m high tank

## HOT PRESS – TRUNCATED EXTERNALLY FLANGED BASE (EFB).



### Tank Support & Clearance Requirements

A Externally Flanged Base tank must be placed on either support walls, steelwork or a combination of both. The top surface of which should be flat, level and free from any local irregularities and should not vary more than 2mm in any 1m or a total of 6mm in any 6m, measured laterally or diagonally.

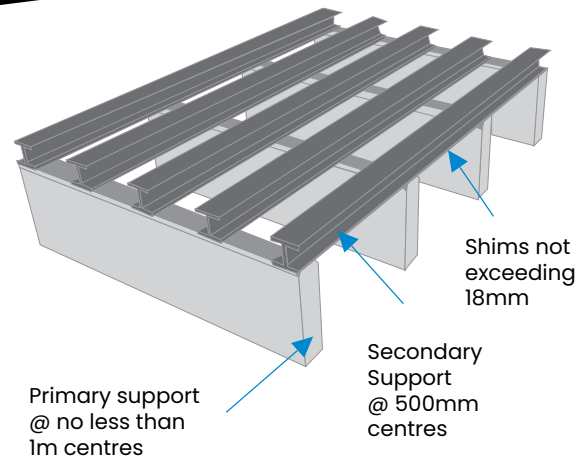

The completed base structure shall be capable of supporting the weight of the tank and its maximum water load i.e. filled to the brim, along with any potential wind or snow loads as applicable.

Alternatively, if the pier tolerance cannot be achieved, the use of levelling steels will allow you take up any irregularities with shims up to a maximum of 18mm. Our standard levelling steels are 100mm x 50mm high galvanised box section and are non-spanning. These arrangements are only suitable for tank heights up to 3m and require pier centres of 1m.

Tank heights of 3.5m & 4m will require secondary steel supports at 500mm centres that will run perpendicular to primary supports (min 500mm high). The size of the secondary steels will depend on the tank height and the spanning distance, please contact us for further guidance.

This arrangement will also be a requirement for tanks with more than one 0.5m lateral dimension e.g. 2.5m x 2.5m.

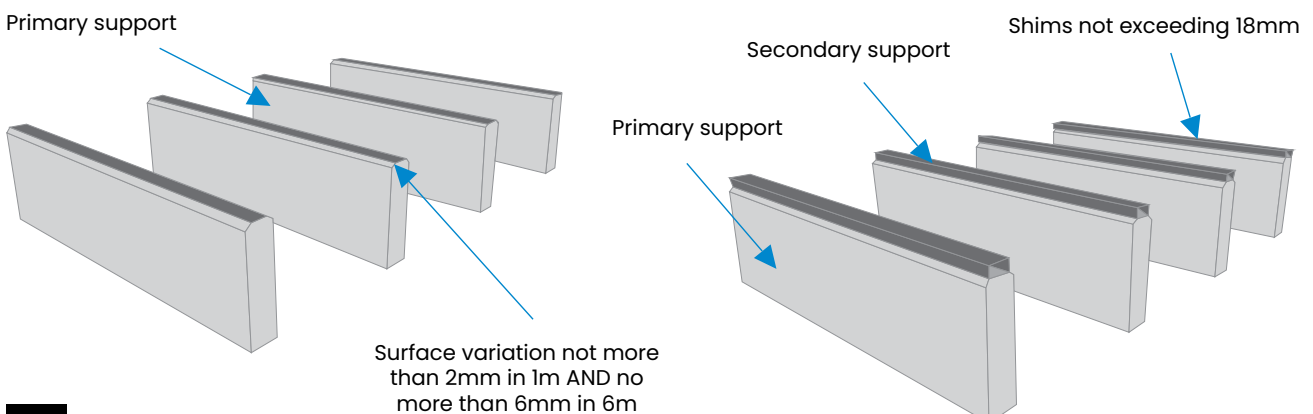

# CLEARANCE REQUIREMENTS.

## For Installation and future maintenance

This style of tank is not suitable for pushing up against a wall, or where there is restricted space or headroom. Listed below are the minimum clearance requirements taken from the internal measurements of the tank:

- 1m & 1.5m = 500mm\* perimeter clearance and 750mm\*\* headroom clearance for safe access.
- 2m > 3m = 800mm\* perimeter clearance and 750mm\*\* headroom clearance for safe access.
- 3.5m & 4m = 1000mm perimeter clearance and 750mm\*\* headroom clearance for safe access.

TANK HEIGHT	CLEARANCE REQUIREMENT
3.5m & 4m	1000mm clearance on all sides
2.5m & 3m	800mm clearance on all sides*
1m > 2m	500mm clearance on all sides*

\*1000mm required on at least one side when fitted with a hooped ladder.

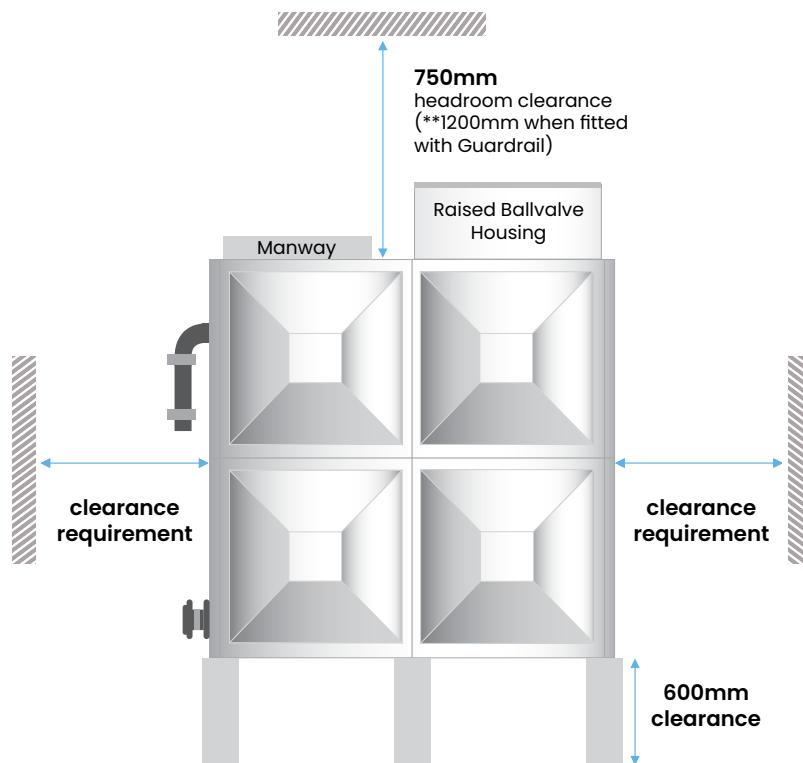

Profile view of typical 2m high tank

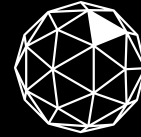

# BOOSTER ENCLOSURE & SECTIONAL TANK.

COMPANY NAME	PRODUCTS/SERVICES SUPPLIED	TANK DIMENSIONS & CAPACITY
CAIRN LODGE HOTEL	SECTIONAL WATER TANK, PUMP SET & ENCLOSURE	2.0 X 1.0 X 1.5

## Scope

This project required the supply & installation of a sectional water tank, pump set and enclosure. The buildings existing water supply was not coping with demand and a last-minute solution had to be provided quickly due to the ongoing lack of water pressure. Time was particularly important due to the hotel welcoming new guests and further demand being placed on the current water supply.

## Solution

Tricel supplied a sectional water tank, a pump set and custom build enclosure to the Cairn Lodge Hotel. Our project team managed this request by working out the required water demand of the building, which dictates the capacity & size of the cold-water storage tank.

We also worked through the pump requirements to ensure there was adequate pressure available for the building. The pump required a housing unit to protect the pump from the elements.

Our team manufactured, delivered and installed the sectional water tank & enclosure on site within the timeframe available to us before the hotel opened.



# Tricel – Looking after your pumping needs

Tricel provides a total solution for all your pumping requirements – from supplying and installing a complete range of pumping systems, spareparts and accessories, to offering a variety of service and maintenance packages.



From our extensive product range we can supply and install pumping equipment for a wide range of applications. Tricel, ISO 9001:2000 accredited, works with some of the worlds largest and most respected manufacturers to deliver the best quality products. With many years experience in the industry the team is well placed to provide knowledge and advice. We can advise on the best solution for particular requirements, install pumping systems and carry out regular maintenance or one-off repairs.

Elvaro water pressure booster units are used in domestic water supplies to residential buildings, office buildings, factories, hospitals, hotels, and schools. Booster water supplies for irrigation, washdown systems and cleaning systems – (Cat 5 air-gap arrangement of the tank is available for these)

## ELVARO B + T Range

**Elvaro B-Range:** The Elvaro B is combined tank and variable speed pump set designed to minimise the space used up by the components of a similar installation where the tank is located alongside the pump set. Variable speed operation of the pumps ensures a longer life of the pipework system due to removal of the water hammer common with fixed speed operated pumps. Mounting the tank on a steel frame above the pumps not only provides a space saving solution but is also an ideal replacement for an existing installation where larger tank capacity can be obtained in the available space.



**Elvaro T-Range:** Variable speed operation of the pressure pump means system pipework lasts longer due to the removal of the water hammer common on fixed speed operated pumps. This also provides a reduction in energy consumption and is much quieter when in operation. The compact design of the unit not only provides a space saving solution, but is an ideal replacement for an existing installation. Smaller units in the range can fit through standard doorways without having to be dismantled. An ideal water pressure pump for the home.

# Complete Pumping & Control Systems



## Pumping Solutions

**At Tricel we have the ability to offer bespoke solutions for any pumping requirement including hand, wind, solar, electric, petrol or diesel driven pumps, for a diverse range of applications and end users.**



Our core objective is to ensure your water flows smoothly by providing high quality pumping solutions for the building services, drainage and sewage, turf irrigation and water utility markets. We also cater for a number of niche markets requiring specialist knowledge including manufacturing, pharmaceuticals, chemical processing and the marine industry.

Together with some of the industry's most respected pump manufacturers, we offer total pumping solutions – either through a pre-packaged pumpset or by designing and manufacturing to specific demands. Our skilled team of specialist engineers can design, assemble and finish pre-packaged and individually specified pumpsets to meet your requirements.

## Commissioning • Site Visits • Repairs

Through a fully equipped service department Tricel Pumping Solutions offers on-site commissioning and installation services of pumping systems – either as part of a complete package or as an add-on service. Our team can handle preventative maintenance contracts or specific repairs – such as the replacement of a seal – or a complete overhaul to leave your equipment functioning like new.

We also offer a variable speed drive fault diagnosis and repair service for most makes of inverter. Our specialist engineers have the capability to carry out repairs both on-site and in our own workshops, we also offer competitively priced replacements, and short term hire.





## Booster Sets

Our range of booster sets ensure a smooth-flowing solution to problems of insufficient volume and water pressure.

Using fixed or variable speed technology our booster sets are designed to deliver sufficient pressure in various applications such as a block of flats, or to prevent back contamination in abattoirs, sewage treatment works or chemical plants where water supply has to be interrupted.



## Pressurisation Sets

Tricel Pumping Solutions serves the building services industry with commercial heating and cooling systems, offering single pump units to twin pump cabinet-enclosed microprocessor control units. With the right system details, we can size, specify, supply, and commission a system to meet your pressurisation needs. We also offer add-ons such as high/low pressure cut-outs and connections to building management systems.

## Vessels

Tricel Pumping Solutions supply vessels for a number of applications. Vessels can form part of a booster set or be used to assist pumps taking up expansion on a heating or chilled system. Tricel Pumping Solutions offer a comprehensive sizing service, serving a range of different sizes up to and including 5,000 litres.



## Pumping Kiosks

Tricel expertise extends to being able to offer the right type of kiosk to house pumping equipment and controls. Available in steel or fibre glass and in a variety of colours and finishes – smooth, textured or simulated brick.

All kiosks adhere to British standards. Larger, walk-in versions can also be supplied, manufactured in fibre glass.



## Wastewater Pumping Systems

### Bespoke packaged pumping stations

**Our bespoke range of fully automatic packaged pumping stations are suitable for pumping ground, surface, storm and foul water to a higher level when gravity drainage is not possible or economical.**

Our bespoke range of fully automatic packaged pumping stations are suitable for pumping ground, surface, storm and foul water to a higher level when gravity drainage is not possible or economical.

When designing a packaged pumping station we carefully consider every aspect to ensure it perfectly matches your project's individual requirements. This includes reliability, longevity and ease of service. Our systems are designed to excel in their task and are built to last.

Our packaged pumping stations can be installed at construction stage or retrofitted to existing buildings. They can accept wastewater from extensions, single dwellings, multi-dwelling housing developments, offices, factories, public buildings, hotels, restaurants, schools, car parks, isolated buildings, sewage treatment plants and more.

#### Key features

- Suitable for all wastewater types
- Available from stock
- Award-winning chambers in 40 sizes up to 2.4 m diameter by 4 m deep
- High quality, long-lasting and robust pumps from leading manufacturers
- Unrivalled quality
- Free no-obligation site surveys
- Full project management from tender through to handover
- Ongoing support for the whole product lifecycle

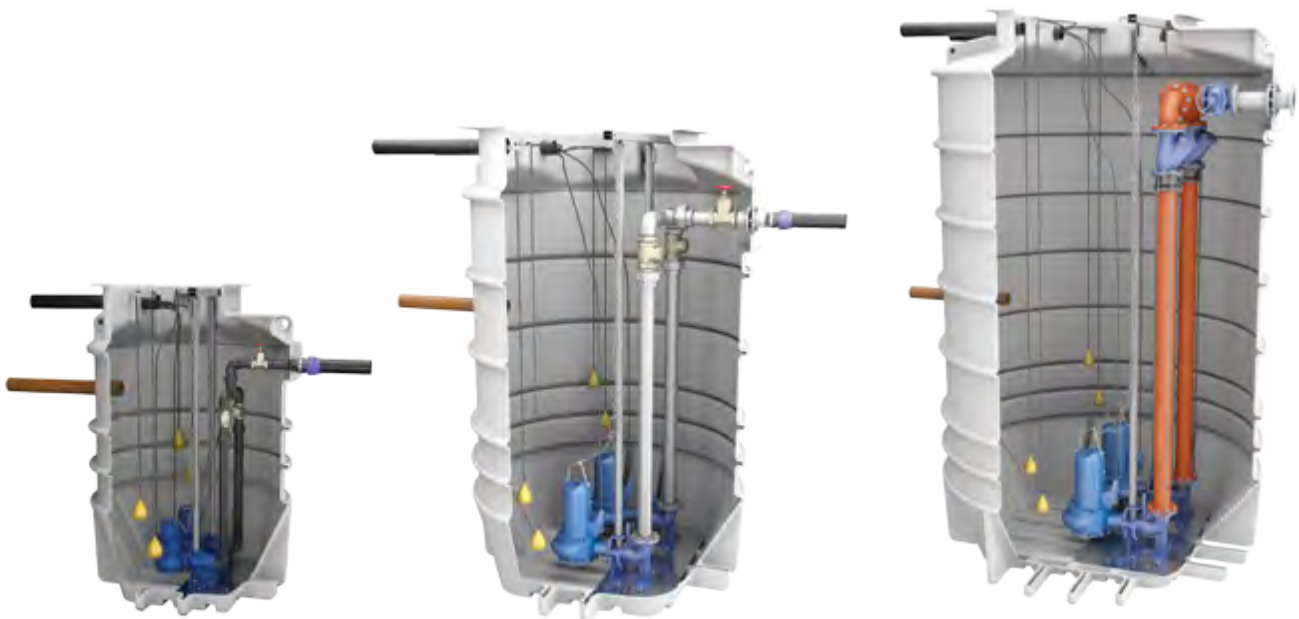



# Introduction to below ground pumping stations

Call 01442 211 554 or email [training@edincare.com](mailto:training@edincare.com) to book a free CPD session at your premises today.

## Turnkey pumping stations



- All wastewater types
- Available from stock
- Wide range to suit all applications
- Choice of alarms and battery backup systems

## Floor mounted pumping stations



- No civils work required
- Single or three-phase
- Single or twin pump
- Variable inlet positions
- Wide range to suit all applications

## Fat, oil and grease separators



- Prevent odours and expensive blockages
- Comply with local authority guidelines
- Market leading performance
- A wide range to suit all commercial kitchens
- Solid waste traps and sediment catchers

## Compact grey water systems



- Versatile range is ideal for kitchens, utility rooms, tea points and laboratories
- Compact tanks for easy installation
- High temperature options
- Stainless steel, polyethylene or high temperature GRP tanks
- Choice of alarms and battery backup systems



**Extensive Range**



**Quality Materials**



**Technical Support**



**Reliability & Durability**



**Technical Expertise**



**Customised Solutions**

# Tricel Environmental

## Wastewater Treatment Systems

### Domestic Wastewater Treatment Plant (1-50 PE) – Tricel Novo



#### KEY FEATURES:

- Our best seller, perfect for new builds and upgrades.
- Compact, low running costs, easy installation, and minimal maintenance.
- Shallow dig tank.
- Plug and Play system.
- SMC tank.
- Certified EN12566-3.

### Commercial Wastewater Treatment Plant (> 50PE) – Tricel Maxus & Maxus Combi



#### KEY FEATURES:

- Large systems used for treating domestic wastewater from villages, cities, hotels, and resorts.
- Maxus Combi : All-in-one wastewater treatment plant for 50+ Population Equivalent.
- Range that will fit any installation requirements and cater to both permanent and temporary installations.

### Septic Tank – Tricel Vento



#### KEY FEATURES:

- Tailored Solutions: Ideal for properties with ample space for percolation areas.
- Zero running costs, easy installation, and low maintenance.
- Certified EN12566-1.

### Secondary Treatment – Tricel Puraflo

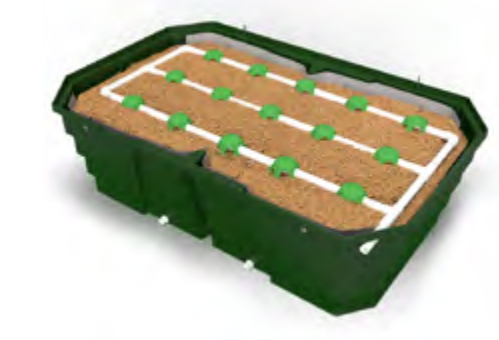

#### KEY FEATURES:

- Compact Efficiency: Suited for compact sites, installed after a septic tank & wastewater treatment plants.
- Very low running costs, easy installation, and minimal maintenance.



# Attenuation and Stormwater Management Systems

## Tricel Rigofill – Crate System



### KEY FEATURES:

- Stormwater Management Systems: Sustainable solutions available in various sizes for specific applications like carparks and roads.
- Suitable for stormwater attenuation & infiltration.
- Universal Components: Rigofill system designed for infiltration, retention, and storage of stormwater runoff.
- Easy installation, camera-accessible, and space-saving with a remarkable 96% water volume capacity.

## Tricel Nerostor – Tunnel System



### KEY FEATURES:

- Underground tunnel stormwater management system.
- Available in four sizes, tailored for site specific needs.
- Engineered to temporarily store excess rainwater, allowing for gradual release into the environment.



Customised  
Solutions

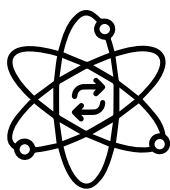

Advanced  
Technology



Reliability &  
Durability

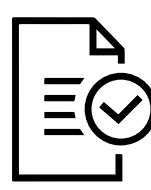

Compliance &  
Regulation

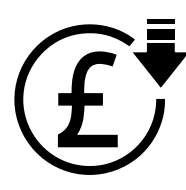

Cost  
Effectiveness

# Construction Products



**TRICEL**  
GENERATIONS OF INNOVATION

## ELECTRIC METER BOXES

We manufacture electric meter box products, including complete boxes, replacement doors, overboxes, covers, and recessed/surface-mounted boxes.

Our in-house meter boxes comply with BS 8567:2012 standards.

Approved by major utilities like Electricity Northwest, Southern Energy, and Western Power Distribution.

Products are in stock for fast nationwide delivery.



## GAS METER BOXES

We offer a range of gas meter boxes available in recessed, surface-mounted, and semi-buried fits.

These external units are ideal for commercial and consumer use, providing excellent weatherproofing and meter protection.

All GRP units are highly durable, hard-wearing, and weather resistant.

Manufactured to meet high standards, including BS 8499:2009



## COMMERCIAL METER BOXES

We offer a full range of commercial meter boxes and IP-rated kiosks in various sizes.

Manufactured from durable, weather-resistant Glass Reinforced Plastic (GRP).

Available flat-packed or assembled, suitable for diverse industrial and commercial uses.

Designed to house switchgears, meters, charging stations, and more.

Can be mounted on poles, concrete plinths, pedestals, and other surfaces.



## ELECTRICAL ENCLOSURES

Engineered for global applicability with water-resistant and corrosion-resistant properties.

Designed to safeguard critical equipment from theft and environmental factors.

Suitable for diverse mounting configurations, including pole mounting and 3 Phase systems.





# Road Safety Products

## TRENCH COVERS



Made from durable, easy-to-clean SMC glass-reinforced plastic.

Trench covers ensure safe access over excavations for pedestrians and light vehicles.

Easy installation with fixing pins for bitumen or butyl adhesive for stone and concrete.

## SUREFOOT TRENCH COVERS

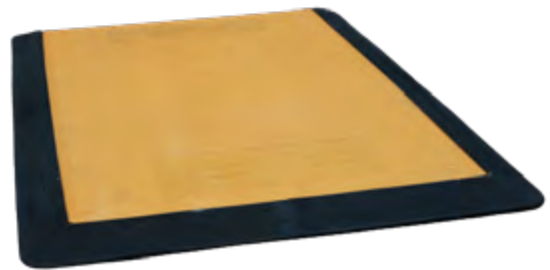

Made from durable SMC glass-reinforced plastic, compliant with HAUC's 2018/01 advice note.

Fully compliant with UK & European legislation, tough, lightweight, and easy to maintain.

Ideal for safe access over site excavations for pedestrians and vehicles up to 3.5 tonnes.

## KERB RAMPS



Made of SMC, making them durable, lightweight, and easy to transport and store.

Fully compliant with all UK and European legislation.

The Kerb Master ramp has a 500kg Safe Working Load (SWL), the highest of any SMC ramp in the utility industry.

## FENCE & LINE PINS



Highly visible on-site to reduce accident risks.

Meets British Standard (BS) 8020 for insulated tools, ensuring safety compliance.

Durable, rust-resistant, and cost-effective by minimizing replacements.

Lightweight, non-conductive line pins protect workers from underground electrical hazards.

# Tricel Distribution



Tricel offers an extensive array of fundamental bulk and wholesale composite materials including resins, topcoats, gelcoats, catalysts, release agents, solvent cleaners (acetone and acetone replacements) as well as glass reinforcements, catering to various manufacturing companies in the Automotive, Construction, Transport and Marine spaces across the UK and Ireland.

As part of the composite construction range, Tricel supplies a range of premium liquid roofing materials under the TriRoof brand. TriRoof caters for the flat roofing market with a comprehensive range of systems (GRP, Modified GRP, Hybrid Polymer, Acrylic and PU), trims and ancillaries.

Tricel Composites are proud to be the exclusive distributors of Coosa Composites' products in the UK, Ireland, and France, ensuring that these superior materials are readily available to our customers. **Coosa Composites** is renowned for its innovative approach to creating durable, lightweight, and versatile composite panels. These products are designed to meet the rigorous demands of various industries, including marine, transportation, and construction.

All of the products listed are supported with on-site training and full technical backup.

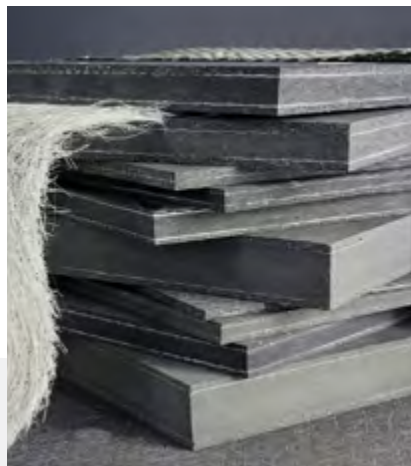

Extensive  
Range



Quality  
Materials

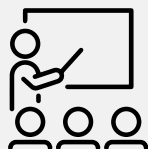

Training  
Available



Excellent  
Value



Technical  
Support



Fast  
Delivery

# Composite Supplies

## GRP Complete System



### KEY FEATURES:

- Premium range of GRP resin and topcoat from 1kg to 20kg
- Glass reinforcement matting and bandages
- Resin is 100% virgin-blend
- 25-year material guarantee for trained installers

## Flex Overlay System



### KEY FEATURES:

- Can be applied to existing roofs (no need to strip back)
- Cold Applied
- 20-year material guarantee
- Suitable for new and existing roofs
- Easy to use and apply
- Multi-surface primer included as part of the system

## HPX Overlay System



### KEY FEATURES:

- Soft cure overlay system, 14kg
- Isocyanate and bitumen-free, no catalyst required
- Adheres to damp surfaces
- Suitable for use under tiles
- 10 & 20 year material guarantees

## Trims & Outlets

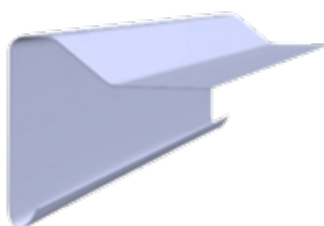

Comprehensive selection of 3-metre GRP Trims including edge, raised, drip, simulated lead flashings and corners. Vertical rainwater outlets in a range of sizes (50,75 & 100mm) with a bonded mesh flange.

## Adhesive & Sealants



Full range of Hybrid Polymer (non-hazardous) and PU Adhesives & Sealants.

- TriGrip Hybrid Polymer Adhesive
- Plasterboard adhesive
- PU combo foam
- Mitre glue

## HPX Repair Kit



- Can be applied to damp surfaces
- Good resistance to UV, water and moisture
- Self-leveling
- Solvent-free, non-flammable
- Apply by brush, roller or squeegee
- Breathable until cured, allowing moisture to evaporate
- Environmentally friendly – Free of bitumen, isocyanate and solvents



# TRICEL

GENERATIONS OF INNOVATION

1484275/2



## WATER STORAGE SPECIALISTS

### TRICEL LANARK

Riverside Road,  
Kirkfieldbank, Lanark, ML11 9JS,  
United Kingdom.

T: +44 (0) 1934 421 477  
E: [sales@tricelwater.co.uk](mailto:sales@tricelwater.co.uk)

### TRICEL WESTON

Winterstoke Road,  
Weston-super-Mare,  
BS24 9AN, United Kingdom.

T: +44 (0) 1934 421 477  
E: [sales@tricelwater.co.uk](mailto:sales@tricelwater.co.uk)

### TRICEL CROYDON

10 Tait Road,  
Croydon, CR0 2DP,  
United Kingdom

T: +44 (0) 1934 421 477  
E: [sales@tricelwater.co.uk](mailto:sales@tricelwater.co.uk)

## PUMPING SOLUTIONS

### TRICEL PORTSMOUTH

Unit 14, Arnside Road, Waterlooville, Hampshire, PO7 7UP, United Kingdom  
T: +44 (0) 196 258 7244 E: [sales@tricelpumps.co.uk](mailto:sales@tricelpumps.co.uk)